

Aurora 2400 and Aurora 5800 Point-to-Point DSSS Digital Radio Links Applications Note

R. U. Laine, P.E. (rlaine@harris.com)
Redwood Shores, CA 94065

Overview

Aurora 2400 and *Aurora 5800* point-to-point direct sequence spread-spectrum (DSSS) digital radios are easily installed, unlicensed (in most countries) wireless equipments for error-free wideband T1 (1.544 Mbit/s) and E1 (2.048 Mbit/s) data transport for North American and worldwide applications.

Spread spectrum technology has accelerated the worldwide total digitization of telecommunications and data networks. These low-cost links are ideal for the rapid turn-up of secure, reliable T1 or E1 wireless trunk extensions

- from higher capacity radio-relay repeater sites and fiberoptics nodes,
- replacing existing 2.1-2.2 GHz (and other) low-capacity analog and digital links,
- between central offices, PABXs, voice frequency and data multiplexers, DAC's, and teleconferencing codecs,
- for cellular MTSO-cell site links,
- for PCS and PCN MSC-BSC-BS-BS interconnectivity,
- within wireless LAN and WAN microcells,
- for Internet Service Provider (ISP) IP and ATM interconnections,
- for mobile, emergency restoration, and temporary service to local and remote areas
- for replacing leased wirelines and other telecommunication facilities within and interconnecting urban and rural areas, and
- for T1 or E1 service throughout the enterprise (private, public, government) communications infrastructure.

This Applications Note provides information relevant to optimally plan, install, commission, and troubleshoot *Aurora 2400* and *Aurora 5800* spread-spectrum digital microwave links.

Many more details on implementing *Aurora 2400* and *Aurora 5800* links can be found in their respective Reference Manuals. [1]



An Aurora 2400 1xT1/E1 DSSS Radio Terminal

ISM Bands - An Historical Perspective

Aurora 2400 and *Aurora 5800* operate in the 2400-2483.5 and 5725-5850 MHz ISM bands for worldwide applications.

The use of these radio spectra was first made effective March 16, 1948 by the FCC (U.S. Federal Communications Commission) when the Rules and Regulations for bands assigned for industrial, scientific, and medical (ISM) purposes were amended to comply with international allocations.

2.4-2.5 GHz ISM Band

This is one of FCC's eight original ISM bands - 915 MHz and 5.85 GHz were also included. The 2.4-2.5 GHz spectrum initially supported medical diathermy, industrial heating, ultrasonic equipments, and various scientific research devices. Later, consumer products such as the ubiquitous microwave oven and many type-accepted (but unlicensed) wireless devices were permitted access to this band, but originally not point-to-point telecommunications links.

This 2.4-2.5 GHz ISM band is now shared with a wide variety of other users, including amateur radio operators, Canadian "Super 2 band" legacy point-to-point radio-relay links to 2450 MHz, devices, wireless microphone, PABX, WAN, and LAN links.

Then, since 1985, unlicensed point-to-point spread-spectrum wireless links typified by the *Aurora 2400* were permitted access to this ISM band, but in the U.S. to only 2483.5 MHz.

2.4-2.5 GHz ISM Band Regulatory Issues

The deployment of spread-spectrum digital radio-relay links in the ISM bands, particularly at 2.4 GHz, may be subject to such emission constraints as EIRP, power input to the antenna, etc., and then perhaps even user licensing, by the regulatory authorities in some countries. Current regulatory issues for *Aurora 2400* spread-spectrum digital link deployment in North America and some ITU-R regions are described in this section.

It is important that the application of wireless radios to any specific country respect that nation's current homologation, licensing, and other equipment and link approval processes. Antenna input power and EIRP constraints described below dictate factory adjustments or professional field installation to ensure regulatory compliance.

United States

The specific FCC Rules and Regulations parts that apply in the U.S. to the multiple shared users of the 2.4 GHz ISM band include:

ISM Equipment, Part 18
Amateur Radio Service, Part 97
Spread-Spectrum Systems, Part 15.247

FCC Part 15.247 effective April 4, 1997 limits the antenna input power to 1 watt (+30 dBm) and puts a moderate constraint upon the effective isotropic radiated power (EIRP) by imposing a new "3-for-1" rule in 2.4 GHz spread-spectrum point-to-point links: [2]

For each 3 dB the antenna gain exceeds +6 dBi, the power input to the antenna is reduced 1 dB from a +30 dBm (1W) maximum

Since this power limit is that into the antenna, the output power of the transmitter may be increased dB-for-dB by its coaxial cable feeder loss.

Aurora 2400's transmitter power output is adjustable, by software command, over +26 to +15 dBm (high power option) and +15 to -10 dBm (standard power) ranges to accommodate EIRP and other regulatory or link (interference coordination, overload, performance, etc.) constraints.

Latin America (Brazil Example)

ISM-band spread-spectrum digital radio-relay links deployed in Latin American countries tend to follow the U.S. regulations. However, while the Ministério das Comunicações (Brazil) also limits antenna inputs to +30 dBm (1W), a +36 dBm (+6 dBW or 4W) maximum EIRP is further imposed. [3]

Canada

Like Brazil, +30 dBm (1W) antenna input power and +36 dBm (+6 dBW or 4W) EIRP constraints are imposed for low-power "licence-exempt" point-to-point DSSS links in this band. [4]

However, as of this date spread spectrum point-to-point links in this 2400-2483.5 MHz ISM band must be licensed by Industry Canada and frequency-coordinated with legacy radio-relay links operating in the 2.40-2.45 GHz "Super 2" band.

But, while Industry Canada's +30 dBm maximum antenna power input remains, the +36 dBm "licence-exempt" EIRP limit does not then apply to these licensed point-to-point spread-spectrum links.

European Union (EU) Community

ETSI's European Telecommunication Standard ETS 300 328 provides the technical characteristics for data transmission equipment using spread-spectrum equipment operating in the 2400-2483.5 MHz ISM band. This standard, which limits the transmitter's EIRP to a miniscule -10 dBW (+20 dBm), applies to the UK, Germany, and other EU community nations. [5]

Aurora 2400's adjustable +15 to -10 dBm standard power output range (adjustable by software command) accommodates ETSI's +20 dBm EIRP restriction. Higher gain antennas (e.g. 34 dBi with 3m dishes) assigned on longer fading paths help compensate for this severe EIRP constraint.

China

While no countrywide standards apparently apply, specific provinces or regions may be unregulated, impose an EIRP and/or antenna input power limit, or enforce ETSI rules, as described above.

Other Countries

Australia (2400-2450 MHz), Japan (2471-2497 MHz), and France (2445-2483.5 MHz), amongst other countries, have proprietary standards for unlicensed spread-spectrum point-to-point wireless links deployed in the ISM band.

Still, many other countries permit the unregulated use of the 2400-2483.5 MHz ISM band for point-to-point wireless links and impose neither antenna power input nor EIRP (antenna gain) limits.

5.725-5.850 GHz ISM Band Regulatory Issues

Unlicensed 5.8 GHz point-to-point DSSS links in North America (U.S. and Canada), China, Brazil, Southeast Asia, et al are not constrained by EIRP limits, although a +30 dBm antenna input power limit is often imposed. But it appears that the EU community has yet to open this 5.8 GHz band to point-to-point radio-relay links.

Other Regions

Users should respect local current regulations since local or regional licensing has been suggested by some authorities. Spread spectrum is a new, fast evolving application for point-to-point digital transport. Changes should be expected!

Spread Spectrum Overview

Often shared with other radio systems and wireless links in many countries, especially in the 2400-2483.5 MHz band, these new point-to-point spread-spectrum radio-relay links exhibit error-free performance and a large tolerance to

- Multipath ("selective") fading,
- Interference ("jamming"), and
- Interception ("loss of privacy").

And, since it usually requires no frequency licensing nor prior coordination in most regions, 2.4 and 5.8 GHz spread-spectrum link deployment is increasingly widespread throughout the world.

A useful definition of spread-spectrum is:

"A means of transmission in which the signal occupies a bandwidth in excess of that necessary to send the information"

Historical

As an improbable historical note, the celebrated Hollywood actress of the 1930-1950s Hedy Lamarr was awarded U.S. patent #2,292,387 (attached at the end of this paper) in 1942 for a "Secret Communication System" under her married name Hedy Kiesler Markey, along with co-inventor renown classical and Hollywood composer George Antheil.

Hedy's seminal invention, the wartime birth of "spread-spectrum", was given away free to the U.S. government. It synchronized the transmitter and receiver frequency-hopping sequence with perforated paper rolls (88 player-piano keys matching the 88 frequencies used - Antheil's contribution) for a secure radio-controlled torpedo guidance system.

In 1957, Sylvania replaced this "piano-roll" synchronization scheme with early electronic computer processors and a new military communications technology was born. From this intriguing top-secret introduction, spread spectrum has a long illustrious history in providing secure, robust (to "jamming" and fading), spectrally efficient military and satellite communications. The FCC modified its Rules in 1985 to permit the commercial use of this spread-spectrum technology.

For these same properties desirable for military use, spread-spectrum is now well established in a variety of civilian applications and represents an area of rapid development in communications.

Perhaps today's most obvious use of spread-spectrum is in the new generation of CDMA cellular and PCS/PCN wireless telephones, where an increased spectrum capacity is claimed with this newer technique over TDMA and GSM.

Spread-Spectrum Technology

Spread-spectrum is not a basic modulation technique in the conventional sense, like AM, FM, QPSK, QAM, etc., but rather a way of spreading this modulated RF energy over a wide frequency band by the rapid:

- frequency hopping (FHSS),
- phase shifting (DSSS),
- pulsed chirp (e.g. radar), or
- time hopping (military)

of the QPSK, etc., modulated RF signal. Hybrid arrangements of these signal spreading techniques are also used by the military.

This wide RF spreading of the RF bandwidth results from a fast pseudo-random noise-like (PN) binary spreading code transmitted (mixed) with, but independent of, the data. The synchronized reception of this PN code at the receiver is for the despreading of the signal and the subsequent recovery of the data along with the suppression of unwanted signals.

Aurora 2400's and *Aurora 5800's* direct-sequence spread-spectrum (DSSS) transmission uses the PN spreading code sequence to phase-modulate the RF carrier across a continuous band of frequencies. Compared to FHSS, DSSS accommodates a higher peak data rate and has more immunity to noise and interference, longer range (higher system gain), and more efficient data throughput.

DSSS links using the same frequency channel can be packed several times more densely than FHSS links using the same hopping sequence. FHSS has a limited

data rate capability of perhaps >1 Mbit/s that favors multipoint wireless LAN applications.

Although the DSSS RF channel bandwidth is wider, it is scalable to higher bit-rates (such as 1.544 or 2.048 Mbit/s) than FHSS. The more efficient choice for point-to-point spread-spectrum applications is therefore direct sequence (DSSS).

Quadrature phase shift keying (QPSK) modulation is used in most DSSS equipments for its compatibility with the PN phase-shifting spreading code. The PN code multiplies times the data to replace each of the four QPSK symbols, increasing spectral efficiency and signal robustness.

Terminology

With spread-spectrum so radically different from other types of wireless radio technologies, it is characterized by unique terminology.

QPSK modulation is defined by its 13.5 dB CNR/CIR (carrier-to-noise/carrier-to-interference ratio) @ 10^{-6} BER and 2 bit/s/Hz RF spectral efficiency.

Along with its QPSK modulation, DSSS signal-spreading category, and PN codes, the *Aurora 2400* spread spectrum radio is further characterized by the following chip (bit element in the PN code) rates - Mc/s, processing gains, power densities, and jamming (interference) margins:

Aurora 2400

Data rate = 1.544 Mbit/s (1xT1)
= 2.048 Mbit/s (1xE1)

QPSK RF symbol rate (non-spread bandwidth)
= $1.544/2 = 0.772$ Mbaud (MHz) – 1xT1
= $2.048/2 = 1.024$ Mbaud (MHz) – 1xE1

Chip rate
= $(0.772)(15) = 11.580$ Mc/s (1xT1, 15 chips)
= $(1.024)(11) = 11.264$ Mc/s (1xE1, 11 chips)

Processing gain, G_P
= $10 \log 11.580/0.772 = 11.76$ dB (1xT1)
= $10 \log 11.264/1.024 = 10.41$ dB (1xE1)

Jamming margin = $G_P - L - CIR$
= $11.76 - 3 - 13.5 = -4.7$ dB (1xT1)
= $10.46 - 3 - 13.5 = -6.0$ dB (1xE1)

Power density = +8 dBm/3 kHz (maximum).

Aurora 5800

Aggregate data rate: 1.664 Mb/s (1xT1)

2.176 Mb/s (1xE1)
3.208 Mb/s (2xT1)
4.224 Mb/s (2xE1)

QPSK RF symbol rate (non-spread bandwidth):
1.664/2 = 0.832 Mbaud (MHz) – 1xT1
2.176/2 = 1.088 Mbaud (MHz) – 1xE1
3.208/2 = 1.604 Mbaud (MHz) – 2xT1
4.224/2 = 2.112 Mbaud (MHz) – 2xE1

Chip rates:

$(0.832)(15) = 12.480$ Mc/s (1xT1, 15 chips)
 $(1.088)(11) = 11.968$ Mc/s (1xE1, 11 chips)
 $(1.604)(11) = 17.644$ Mc/s (2xT1, 11 chips)
 $(2.112)(11) = 23.232$ Mc/s (2xE1, 11 chips)

Processing gain, G_P

= $10 \log 12.480/0.832 = 11.76$ dB (1xT1)
= $10 \log 11.968/1.088 = 10.41$ dB (1xE1)
= $10 \log 17.644/1.604 = 10.41$ dB (2xT1)
= $10 \log 23.232/2.112 = 10.41$ dB (2xE1)

Jamming margin = $G_P - L - CIR$

= $11.76 - 5 - 13.5 = -6.7$ dB (1xT1)
= $10.41 - 5 - 13.5 = -8.0$ dB (E1, 2xT1/ E1)

The above values are used to ensure compliance to regulatory requirements and for interference computation purposes. The *Aurora 2400* and *Aurora 5800* are compliant to the FCC minimum spread-spectrum processing gain of 10 dB and maximum power density into the antenna of +8 dBm in any 3 kHz band.

Assuming a 5 dB implementation (deviation from theoretical) loss, L, *Aurora 2400*'s and *Aurora 5800*'s jamming margins are about 6.7 and 8 dB below (negative values) the RF carrier for 1xT1/E1 and 2xT1/E1 data rates respectively.

This characterizes the robustness of the spread-spectrum radio as compared to a QPSK digital link without spread spectrum. The allowable interference level into a spread-spectrum 1xT1 receiver is about 6.8 dB higher than into a QPSK digital receiver without spread-spectrum:

$CIR_{DIGITAL} = 13.5$ dB @ 10^{-6} BER (QPSK)
 $CIR_{DSSS(T1)} = 6.7$ dB @ 10^{-6} BER (DSSS - 1xT1)

This 6.8 dB improvement (greater robustness) permits a higher density of spread spectrum links out of a common node or in an urban area than with QPSK digital links without spread spectrum.

Low Data Rates

While not applicable to *Aurora 2400* and *Aurora 5800* links, it is interesting to note that if the chip rate-to-data rate ratio was larger, as in low data-rate CDMA (spread-spectrum) cellular and PCS/PCN wireless networks with long PN code sequences, positive jamming margins actually result. Interference levels 10-20 dB above the wanted signal then exist without disturbance.

With a very long PN code sequence for privacy, this is the basis for a perhaps X3 increase in spectral efficiency claimed by CDMA operators over competing TDMA and GSM techniques.

PN Code Selection

Aurora 2400 and *Aurora 5800* each has four preset PN spreading codes (plus many assigned custom codes) from which to chose. Different PN spreading codes on nearby co-channel links will ensure interlink privacy.

However, the assignment of different PN codes to adjacent or nearby links will not lower interference levels. Co-channel interference may degrade receiver thresholds and thus reduce fade margins which increase multipath outage in *Aurora 2400* and *Aurora 5800* links - but usually not beyond the link's outage objective.

Antenna and Feeder System Selection

FCC, Industry Canada, ETSI, and other regulations for spread-spectrum links in the 2.4-2.485 and 5.725-5.85 GHz ISM bands specifically disallow any field changes to the transmitters or antenna systems that would be in violation to the equipment type-acceptance conditions and RF emission limitations. This dictates the professional field installation of *Aurora 2400* and *Aurora 5800* radios terminals in secure locations.

2.4 GHz ISM Band Constraints

Many countries enforce 2.4 GHz EIRP (e.g. +20 dBm in ETSI regions; +36 dBm in Canada and Brazil) and/or antenna input power (e.g. FCC's "3-for-1" rule) constraints. In such regions, the exacting selection of the antenna gain (size), coaxial feeder loss (type), and transmitter power output (high, low - software adjustment) of the radio is necessary.

In both cases, transmitter power outputs and antenna gains may be increased by the amount of the coaxial feeder loss.

Tables of *Aurora 2400* performance (outage time, SESR) vs. antenna selection, path length, geoclimatic conditions, power output, etc. are available for FCC, ETSI, and "non-regulated" (no antenna power input or EIRP constraint) regions. [7]

Coax and Waveguide Feeder Systems

Non-pressurized ½-inch LDF (foam) coax (or equivalent) is the usual feeder for connecting *Aurora 2400* and *Aurora 5800* radios to their respective antennas. Other feeders available to accommodate user fade margin and performance (outage) objectives and regulatory (EIRP, antenna input power) constraints for these links include the following types:

2.4 GHz foam coax:

3/8" - 5.8 dB/100ft, 18.9 dB/120m

½" - 3.8 dB/100ft, 12.6 dB/100m

5/8" - 2.2 dB/100ft, 7.3 dB/100m

7/8" - *Same as 5/8"*

1¼" - 1.6 dB/100ft, 5.3 dB/100m

5.8 GHz foam coax:

3/8" - 9.6 dB/100ft, 31.6 dB/100m

½" - **6.5 dB/100ft, 22.6 dB/100m**

5/8" (new) - 4.7 dB/100ft, 15.4 dB/100m

5.8 GHz waveguide:

EW64 - 1.8 dB/100ft, 5.9 dB/100m

EW63 - 1.5 dB/100ft, 4.9 dB/100m

EW52 - 1.2 dB/100ft, 3.9 dB/100m

The standard coaxial feeders provided with *Aurora* radios are shown in bold in the above table. Other types and sizes may be selected, of course.

Interference Considerations [11]

While it is expected that *Aurora 2400* (especially) and *Aurora 5800* links will be deployed in urban areas that are (or will be) frequency-congested, the robust nature of the digital modulation and spread spectrum technology should mitigate most discernable customer traffic degradations caused by interference.

However, good engineering judgment should be used before selecting locations near equipment or facilities that could generate interfering signals. These might even include microwave ovens and other high power ISM devices. Appropriate caution should be exercised in deploying links in the same region as large numbers of other 2400 and 5800 MHz point-to-point or point-to-multipoint links.

In some interference cases, threshold degradation causing an increase in short-term multipath outage or a slightly degraded residual bit error rate (RBER) may occur, either or both of which can probably be tolerated.

As a general rule, the deployment of a larger antenna with a smaller beamwidth and higher front-to-back ratio, an antenna relocation for better interference shielding, or a polarization change is often very effective in mitigating most interference cases.

These are discussed in a later section. Such field changes, to respect the interference ambient and to otherwise improve *Aurora 2400* and *Aurora 5800* link performance, require no prior regulatory approval in unlicensed links.

2.4 GHz Antenna Selection

Low-cost grill-type rectangular parabolic grid antennas with about 24 dBi gain have been standardized for use with the *Aurora 2400*.

However, a large selection of other 2.4 GHz antennas with higher gain (up to 15ft/4.7m dishes with almost 39 dBi gain!), lower gain, panel, helix, wide beamwidth, etc. as well as other standard round aperture grid and solid dishes are also available for deployment in *Aurora 2400* links

Low-gain (e.g. 18 dBi) 2.4 GHz circularly polarized helix antennas may be deployed on overwater paths to greatly reduce fade depths from specular multipath reflections. However, the cross-pol discrimination between linear V- or H-pol and circularly polarized signals is only 3 dB, so use appropriate caution in deploying helix antennas in congested areas.

Even though the transmitter power output may be lowered to accommodate regulatory rules, larger antennas are recommended on the longer fading *Aurora 2400* hops. The higher antenna gains will apply to the receiver (“non-regulated”) end of the path for more fade margin and reduced outage.

U.S. 2.4 GHz “3-for-1 Rule” Example

Assume a 19-mile/30-km link with a high-power ($P_o = +26$ dBm) *Aurora 2400* transmitter coupled to a low-cost 24 dBi gain, G_T^1 , grid antenna through 50 ft/15 m of ½-inch LDF coax (about 2 dB loss, L_T).

The FCC’s “3-for-1” rule requires a 1 dB reduction in the antenna input power below its +30 dBm maximum for each 3 dB increase in antenna gain above +6 dBi. Thus, *Aurora 2400*’s allowable output power $P_o = 30 + L_T - (G_T - 6)/3 = 30 + 2 - (24 - 6)/3 = +26$ dBm. This link is thus FCC-compliant with no output power reduction.

The link’s fade margin = $P_o - L_T + G_T - L_P + G_R - L_R + 92$, dB. The receive signal level (RSL) and fade margin (to the -92 dBm 10^{-3} BER outage point) on this 19 mi link (130 dB path loss) is thus computed as -60 dBm and 32 dB respectively. This provides a 99.99934% path reliability (~200 SES/yr outage) in this

good propagation area (geoclimatic factor $c = 1$; $t = 50^\circ\text{F}$).

Aurora 2400 output power reductions are not required on shorter paths with lower gain antennas and/or longer or more lossy coaxial feeders.

However, larger (even much larger) antennas are recommended on longer fading hops even if the power inputs to the antennas are marginally reduced per the “3-for-1” rule. The larger antennas increase antenna gains (and thus the RSL’s and fade margins) for lower outage on these links.

ETSI (European Union) “EIRP Limit” Example

ETSI’s much lower +20 dBm EIRP limit for 2.4 GHz ISM-band links dictates the deployment of only standard power (low-power option) *Aurora 2400* radios in these regions.

The link’s fade margin = EIRP (+20, in ETSI; +36 in Canada and Brazil) - $L_P + G_R - L_R + 92$, dB.

With the above antenna feeder systems, +24 dBi antenna gains (G_T and G_R) and 2 dB coax losses (L_T and L_R), *Aurora 2400*’s output power is reduced to $20 - 24 + 2 = -2$ dBm, a 17 dB reduction from its standard +15 dBm low power output. *Aurora 2400*’s output power adjustment range is +15 to -10 dBm thus accommodates ETSI’s +20 dBm EIRP limitation.

While the computed RSL and fade margin on a 10 km path is only -78 dBm and 14 dB respectively due to ETSI’s severe EIRP limitation, only ~150 SES/any-month outage (SESR = 0.000059) is expected in a favorable geoclimatic area.

5.8 GHz Antenna Selection

There are neither antenna power input nor EIRP constraints in North America and in most other regions that allocate this band for unlicensed point-to-point radio-relay applications that limit the gain (size) of 5.8 GHz antennas.

While a low-cost 28 dBi flat panel antenna has been selected as standard with the *Aurora 5800*, any other 5.8 GHz antenna may be used. Most *Aurora 5800* applications deploy non-pressurized antennas with N-type fittings for connection to foam coaxial feeders, however.

Performance, Clearance, and Interference

The performance of *Aurora 2400* and *Aurora 5800* links are characterized not unlike that of any conventional 2 or 6 GHz point-to-point non-diversity microwave link. Ref. 6 lists various availability and outage models and objectives from which to select.

² Notation: G_T, G_R - Transmit and Receive Antenna Gains
 $L_P, L_T, \text{ and } L_R$ - Path and Coax Losses
 P_o - *Aurora 2400* Transmitter Power Output

While the "Short Haul" objective (about 27 min/yr or 9 min/any month end-to-end one-way T1/E1 trunk outage) may be suitable for most applications, *Aurora 2400* and *Aurora 5800* radios are often used for temporary links or as alternatives to copper wire services.

A higher outage objective may therefore be assigned to a DSSS link, resulting in significant cost of antennas and support structures savings.

Aurora 2400's and *Aurora 5800's* wide, robust transmitted spectra reduce the probability of multipath fade outage on these links. In sharp contrast to FM analog radio links where the RF carrier disappears, or a broadband QPSK or other digital links where increased multipath outage occurs with signal distortion (dispersion), spread spectrum signals are not nearly as affected by multipath notches.

Aurora 2400's and *Aurora 5800's* dispersive fade margins (DFMs), the measure of its sensitivity to path-generated spectrum distortion, exceed 60 dB and are thus disregarded in link performance calculations.

For this reason, the addition of diversity protection to lower multipath fade outage is rarely necessary to meet performance objectives.

Hot Standby and Paralleled Link Operation

In the event that equipment protection is needed, co-channel dual polarized (CCDP) *Aurora 2400* or *Aurora 5800* radios on cross-polarized or horizontally separated antennas with T1 or E1 span line switches are suggested. Vertically separated antennas (paths) to provide a reduction in multipath outage (space diversity) are not recommended because of differential fading intralink interference and also because T1/E1 span-line switching is not hitless.

Of course, without the T1/E1 line switch the capacity of paralleled *Aurora* links is doubled in this manner.

Path Clearance and Reliability

As a general rule, spread-spectrum links can be assigned about the same $0.6F_1 @ k=1^2$ path clearance as standard (licensed point-to-point analog and digital radio-relay links) in the 2 and 6 GHz bands.

² "k" is the ratio of the radius of curvature (refractivity) of the radio path to that of the earth. A $k = 1$ (no refractive ray bending over a true earth) is commonly used for longer paths. However, a $0.6 F1 @ k = 4/3$ ds unobstructed path, typical for shorter paths, and even slightly obstructed paths, are also very acceptable on most other *Aurora* links.

Tables of link reliability under different conditions of terrain, climate, antenna size and path distance is available from Harris. [7] The received signal level and path reliability (outage, SESR) results under a wide variation of link design conditions can be determined using Harris MCD's *StarLink 2* computer program. [8]

But most *Aurora 2400* links with lower, but perhaps antenna-to-antenna visual line-of-sight, (i. e. grazing or slightly obstructed) clearance between antennas, will usually exhibit error-free performance and low fade activity.

And since many *Aurora 2400* and *Aurora 5800* links are shorter and non-diversity, such lower-clearance paths over reflective terrain (open fields, lakes, etc.) are usually more stable (fade-free) than those with excessive path clearance.

2 GHz microwave links which have slightly below line-of-sight mid-path clearance, perhaps through trees, usually exhibit excellent performance with minimal fade activity. Low obstruction losses in the 2-6 dB range - a loss dependent on the tree density or size and location of the obstacle - are typical of such low-clearance paths.

These obstruction and "sneak path" losses increase with frequency, of course, so adequate path clearance assignment (usually $0.6F1 @ k=4/3$ ds) is somewhat more important to *Aurora 5800* links.

Reliability (path outage) calculations under different path clearance and geoclimatic conditions are easily accomplished with commonly available software products, such as Harris MCD's *StarLink 2* shareware personal path engineering computer program that is available at no cost. [6]

Interference

The effect of an interfering signal into a digital radio receiver is characterized by a 1 dB degradation (rise) in the $BER = 1 \times 10^{-6}$ (static) and 1×10^{-3} (outage) thresholds. The standard for this characteristic is the threshold-to-interference (T/I) ratio curve seen below, as defined in EIA/TIA Document TSB-10-F. [9]

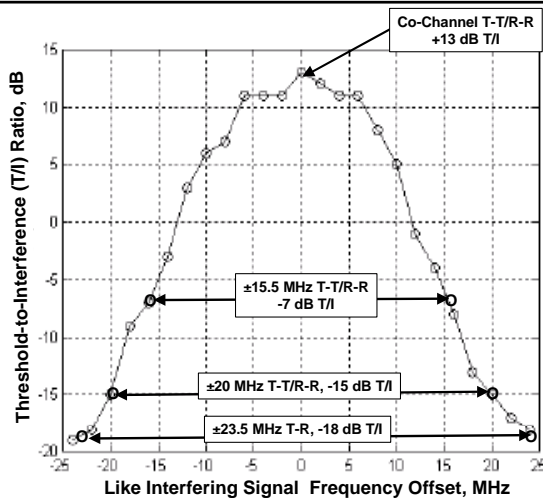

Aurora 2400 T/I Curve

The allowable level of interference into any digital radio is determined by its T/I characteristic, threshold, and fade required fade margin. The interference level degrading the victim radio's threshold (fade margin) by 1 dB is:

$$I = \text{Victim Receiver's } 10^{-6} \text{ BER Point} - T/I, \text{ dBm}$$

Co-channel interference example, with the Aurora 2400 radio's 10^{-6} BER static threshold = -90 dBm:

$$I = -90 - 13 \text{ (see following T/I chart)} = -103 \text{ dBm}$$

The C/I (e.g. the interfering transmitter's or victim receiver's antenna discrimination at a hub repeater site) is:

$$C/I = \text{Required Fade Margin} + T/I$$

Again, this same co-channel interference case, but assuming a 25 dB fade margin is required to meet link performance objectives:

$$C/I = 25 + 13 = 38 \text{ dB}$$

From the above T/I curve, *Aurora 2400* T/I objectives are about +13 dB co-channel and -18 dB and adjacent (± 23.5 MHz T-R) channel for "like" DSSS interference. "Like" means the interfering signal is also spread across *Aurora 2400's* 20 MHz bandwidth.

T/I curves are also available for the 1xT1/E1 and for the 2xT1/E1 versions of the *Aurora 5800* radio with their 20 MHz and 40 MHz RF bandwidths respectively and where the T-R separations at hub sites are 25 and 31 MHz respectively. *Aurora 5800's* co-channel T/I is about 10 dB.

The interfering effect of the *Aurora 2400* and *Aurora 5800* signals into other QPSK DSSS receivers, about

the same as interference into these receivers, is also verified with appropriate T/I charts.

Aurora 2400 and *Aurora 5800* interference into receivers other than point-to-point which share these ISM bands, such as wireless LANs and PABXs, is negligible. These narrower-bandwidth links, inside buildings or over short, non-fading paths, are rarely affected by outside signals.

2.4 GHz Multi-Link and Hubbing Arrangements [11]

With the very close T-R RF channel assignments in the 2.4 and 5.8 GHz ISM bands, frequency assignments at *Aurora 2400* and *Aurora 5800* repeater and hub sites are sometimes complex. Ref. 11 (*Interference Considerations at Aurora 2400 and Aurora 5800 Hubbing Sites*) covers this subject in detail. This document should be used as the bases for *Aurora 2400* and *Aurora 5800* frequency assignments and antenna engineering.

Aurora 2400 1xT1 DSSS radios for U.S point-to-point links are assigned to the channel pairs A and/or B in the 2.4 GHz ISM band as shown in the following sketch. *Aurora 2400's* B2 channel for CEPT 1xE1 links is 2473.5 MHz.

With only 23.5 MHz T-R frequency separation using both the A and B channels at a hub site, *Aurora 2400's* low-cost standard grid antennas (15, 19, and 24 dBi gains) must be physically separated.

A and B Channels (U.S. Plan)

2.4 GHz U. S. ISM Band Frequency Channel Plan
Possible Intrasite T-R Interference Case

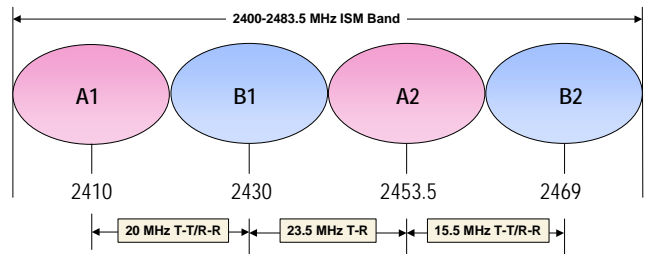

Pair A: 2410/2453.5 MHz
Pair B: 2430/2469.0 MHz

Two channel pairs (2410/2453.5 MHz and 2430/2469 MHz in North America and 2410/2453.5 and 2430/2473.5 MHz internationally) provide 20 MHz T-T/R-R separations at *Aurora 2400* repeaters and hub sites.

Aurora 2400 and Aurora 5800 Co-Channel Interference

However, co-channel interference coordination between independently fading *Aurora 2400* or *Aurora 5800* links requires only about 38 dB of inter-link antenna discrimination at repeater and hub sites. The following rectangular grid antenna pattern shows this discrimination (C/I) is met with $>10^0$ azimuth difference between the links with co-channel X-pol assignments.

Grid Antenna X-Pol RPE (H-pol)

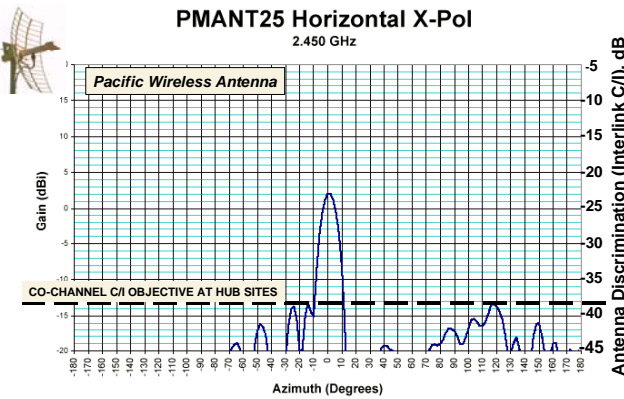

There is no T-R interference since *Aurora 2400*'s standard Pacific Wireless 24 dB gain grid antennas provides this discrimination on cross-polarized paths with $>10^0$ angular difference out of a repeater site. Co-channel assignments for both links out of repeater site are therefore highly recommended.

5.8 GHz antennas have even higher discriminations, so *Aurora 5800* co-channel assignment links out of a hub site are also recommended

Aurora 2400 Adjacent Channel T-R Interference

However, adjacent channels A and B can be assigned at a repeater or hub site by mounting *Aurora 2400*'s low-cost grid antennas on the opposite sides of a building or elevator machinery structure or by wide ($>20\text{ft}/6\text{m}$) antenna separation.

The >100 dB T-R antenna isolation objective for 1 dB fade margin degradation with 23.5 MHz intrasite T-R separation is usually achieved with interfering path blockage added to the antenna discrimination.

The number of *Aurora 2400* and similar links assigned out of a hubbing or repeater site thus depends upon the following factors:

- RF channel assignments and pairings
- Required link fade margins. A moderate loss of fade margin due to interference into a short or oth-

erwise low fade activity *Aurora 2400* or *Aurora 5800* hop is often acceptable. Link outage objectives are usually met with lower fade margins.

- Antenna discriminations (front-to-back, sidelobe, etc.).
- Building blockage. Interference levels are lowered 10-20 dB or much more with antennas placed on the opposite sides of a building or elevator/stairwell building on the roof.

Paralleled Aurora 2400 and Aurora 5800 Links

As previously discussed, T1/E1 capacity or the equipment protection of two *Aurora 2400* or *Aurora 5800* radios on the same frequency pair may be paralleled on a single path with cross-polarized single or dual-polarized antennas. If the antennas are at the same elevation, cross-polarized paths fade together, ensuring that the 15 dB minimum C/(N+I) ratio objective for no errored seconds will be met during fade activity.

5.8 GHz Multi-Link and Hubbing Considerations

Three frequency pairs are available to 1xT1/E1 and two pairs are available to 2xT1/E1 *Aurora 5800* links. Since 5.8 GHz antennas have considerably higher gains and F/B ratios, and much narrower beamwidths, intra- and inter-link frequency coordination in this band is considerably easier than in *Aurora 2400*'s 2.4 GHz ISM band.

Aurora 5800 2xT1/E1 Channel Assignments

Two 30 MHz bandwidth full duplex channels are available for *Aurora 5800* 2xT1/E1 links, as seen in the following sketch.

Aurora 5800 2T1/E1 Channel Plan

5.8 GHz 2xT1/E1 Frequency Channel Plan Possible Intrasite T-R Interference Cases

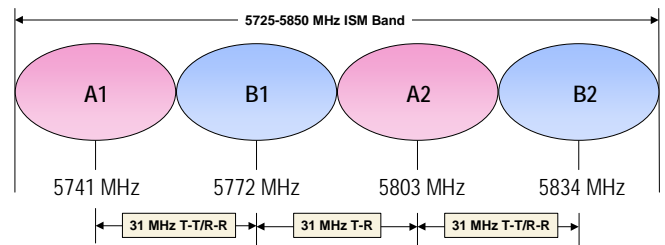

Pair A: 5741/5803 MHz
Pair B: 5772/5834 MHz

Since the small 31 MHz T-R separation between the B1 and A2 channels requires about 100 dB of isolation between T-R antennas at a hub site, co-channel assignments on links out of hub site is recommended.

Both the A and B channels could be used at a repeater or hub site if the antennas are high performance (shrouded), separated, or shielded by building blockage.

Aurora 5800 2xT1/E1 Channel Assignments

Three 20 MHz bandwidth full duplex channels are available for assignment to 1xT1/E1 Aurora 5800 links as seen in the following sketch.

Aurora 5800 1T1/E1 Channel Plan

**5.8 GHz 1xT1/E1 Frequency Channel Plan
Possible Intrasite T-R Interference Cases**

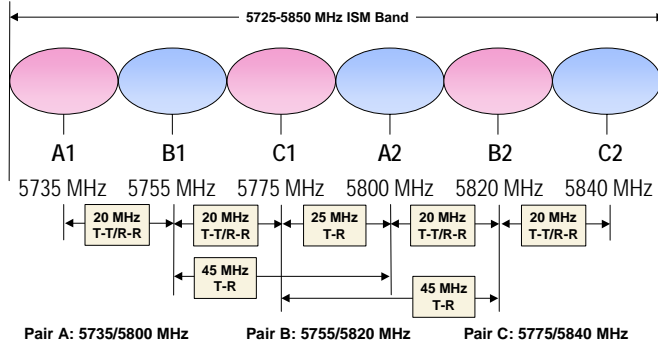

It is highly recommended that only channel pairs A and B or B and C be assigned to 1xT1/E1 Aurora 5800 links out of a hub repeater site. There is no intrasite T-R interference between these channels and thus no antenna size, type, or positioning constraints.

The assignment of channels A and C to different links at a hub site result in a 25 MHz T-R interference case requiring careful antenna selection and/or positioning to prevent fade margin degradations to the victim links.

Assistance

Harris Microwave Communications Division can provide rapid assistance in the optimum selection of antenna feeder systems for any specific Aurora 2400 or Aurora 5800 application which meets regulatory and performance objectives.

Applications

Aurora 2400 and Aurora 5800 links can be deployed to a great variety of communications applications where the following are critical factors:

- Competitive price
- Quick deployment with packaged antenna hardware with small radios and antennas
- Security, performance, and availability
- Interference protection afforded by DSSS

Networking Examples

Low-cost Aurora 2400 and Aurora 5800 spread-spectrum links provide an ideal rapid turn-up, secure, reliable, wireless solution for T1 or E1 transport in many telecommunications networks.

The following sketches illustrate but a few of the many networking arrangements possible using highly flexible Aurora 2400 and Aurora 5800 links.

Local and Rural Telephone

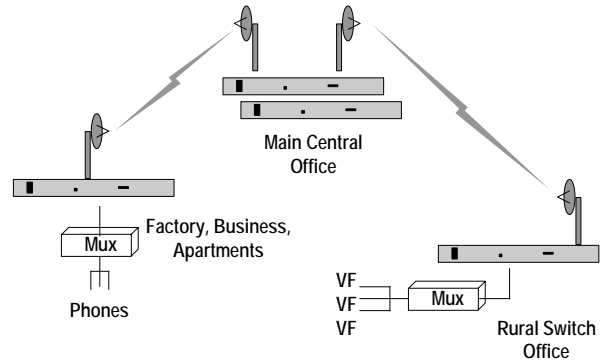

The above application shows "last-mile" access established between a telephone central office (CO) switch and urban user locations or rural users served by a remote switch. Short or long (>30mi/50km) links can be designed to provide reliable circuits to telephone subscribers.

Cellular and PCS/PCN

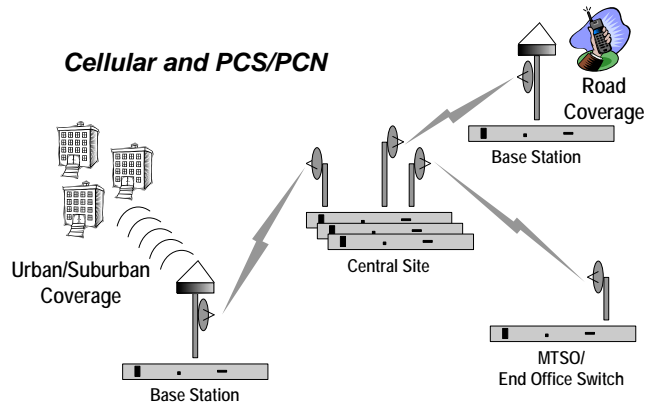

The above diagram illustrates the interconnection of a cellular or PCS/PCN base station to a central switch location to increase cellular coverage at low cost. Several links can be extended from a hub location. The number of spur links and angular offset between these links depend upon the specific characteristics of the selected antennas, as previously discussed.

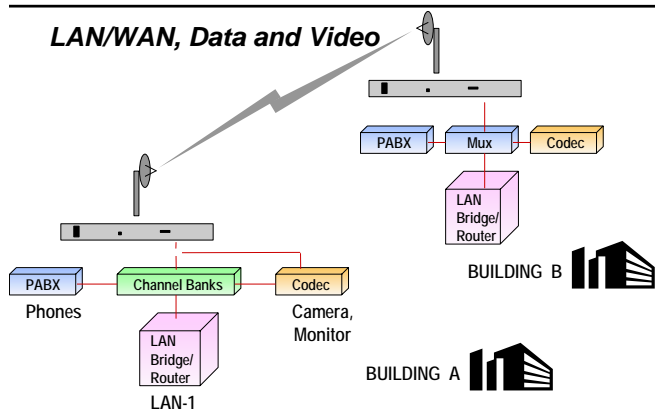

A third popular application, above, is the provision of wireless access to IP, voice, data, and video circuits in different business locations. Voice and low-speed data circuits, 384 kbit/s teleconferencing lines, etc. are connected with PCM channel banks. LAN/WAN bridges and routers can be directly interconnected with *Aurora 2400* and *Aurora 5800* radio terminals.

In addition to these applications, *Aurora 2400* and *Aurora 5800* links are ideal backups for such critical communications as land mobile, public safety, and emergency services.

Economic Considerations

Aurora 2400 and *Aurora 5800* microwave transport offers significant technical and economic advantages over conventional copper- or fiber-based leased or owned transport alternatives when availability, cost-effectiveness, implementation time, security, and difficult terrain or access are significant network design considerations.

Ref. 10 describes how the economic and technical challenges of creating a new telecommunications infrastructure are met more effectively with point-to-point radio links than with traditional wireline-based solutions.

Four factors are considered when comparing *Aurora 2400* and *Aurora 5800* digital transport facilities to conventional leased line services:

- Transmission Quality and Reliability
- Circuit Availability
- Short Haul Costs
- Construction Time

The infrastructure of most telephone networks has inherent regulatory and technical characteristics that limit its ability to meet microwave's superior transmission quality, reliability, and other performance and availability characteristics.

It is not unusual for the telephone company's "local loop" subscriber facility to have a "residual bit error rate" (RBER) some 100 times or more worse than microwave links along with a long-term outage (unavailability) measured in hours per year. Simple and highly reliable *Aurora 2400* and *Aurora 5800* microwave links can provide customers with superior service.

Microwave's short-term reliability standards, in excess of 99.995% - 99.999% (a few minutes outage per year), are often significantly better than that possible with than typical leased copper services.

The purchase price of an *Aurora 2400* or *Aurora 5800* link can be paid back in approximately two years compared to the cost of a wireline monthly lease. This pay-back period will vary by region because of differing wireline tariff rates. Considering the competitive cost, unequalled reliability, and shorter installation time, a purchased *Aurora 2400* or *Aurora 5800* microwave link remains the clear choice over leased line service.

Conclusion

This Applications Note has described *Aurora 2400* and *Aurora 5800* radios that can provide low-cost, rapid turn-up, secure, and reliable wireless links in the unlicensed 2.4 and 5.8 GHz ISM bands. The historical background and selected regulatory examples with spread-spectrum's technology and unique digital modulation technology were discussed.

This Applications Note also addressed typical link performance, path clearance, and reliability objectives.

In summary *Aurora 2400* and *Aurora 5800* links are the reliable, cost effective solutions for many communications applications.

References

1. "Aurora 2400 and Aurora 5800 Reference Manuals", Harris Corporation, Microwave Communications Division, Harris Doc. RMN-2853-E05, 7/00.
2. United States Code of Federal Regulations Title 47, Part 15.247, U.S. Government Printing Office, 4/97.
3. Ministério das Comunicações (Government of Brazil) Norma 12 / 96, 7/96.
4. Industry Canada Radio Standards Specification RSS-139, "Low Power Licensed Radiocommunication Devices in the Band 2400-2450 MHz", Issue 1 (provisional), 2/99. Also, RSS-210, "Low Power Licence-Exempt Radiocommunication Devices (All Frequency Bands)", Issue 3, 2/99.

5. European Telecommunications Standards Institute (ETSI) ETS 300 328, 'Radio Equipment and Systems (RES); Wideband transmission systems; Technical characteristics and test conditions for data transmission equipment operating in the 2.4 GHz ISM band and using spread spectrum techniques", 11/96.
6. R. U. Laine and A. R. Lunan, "Digital Microwave Link Engineering - Performance Definitions and Objectives", Entelec'94, San Antonio, TX, 3/94. Harris Tech. Doc. No. 215.
7. R. U. Laine, "*Aurora 2400* Multipath Reliability and Distance Charts", 9/00. Harris Tech. Doc. No. 220.
8. "StarLink 2" computer program for North American and ITU-R radio-relay path engineering, available cost-free by download from the Harris Microwave Communications Web site. Just click on or enter: <http://www.microwave.harris.com/starlink>
9. TIA/EIA Telecommunications Systems Bulletin TSB-10-F, "Interference Criteria for Microwave Systems", Washington, DC, 5/95.
10. D. Docherty, "Why Microwave Makes Sense For Short Haul Transport in Cities", 5/96, Harris Tech. Doc. No. 117.
11. R. U. Laine, "Interference Considerations at *Aurora 2400* and *Aurora 5800* Hubbing Sites", Harris Corporation, Microwave Communications Division PowerPoint presentation, 4/01.

